

Product: High Power Polarization Maintaining Tap Isolator + BP

Part Number	Spec Number	Version	Date
HPMTIBPXXXXXXXXXX	S139	Rev 01	1/04/2024

1 Specifications

Item	Parameters	Symbol	Value	Units	Note
1.	Center Wavelength	λ_c	1030 or 1064	nm	
2.	Min. Pass Bandwidth @ -0.5 dB		8 14 22	nm	
3.	Max. Stop Bandwidth @ -25 dB		20 48 50	nm	
4.	Max. Excess Loss, λ_c nm, 23 °C	EL	1.0	dB	
5.	Tap Ratio, 23 °C		0.1 ± 0.05, 1 ± 0.2, 5 ± 1.0, 10 ± 2.0	%	
6.	Min. Isolation, λ_c nm, 23 °C (O-I)	ISO	25	dB	
7.	Min. Extinction Ratio, 23 °C (I-O)	ER	18	dB	
8.	Directivity	DIR	50	dB	
9.	Min. Return Loss	RL	50	dB	
10.	Max. Optical Power for I-O	Pop	100	W	
11.	Max. Peak Power for ns Pulse	Pp	10	kW	
12.	Fiber Type		PLMA-GDF-10/125-M or Specify		
13.	Operating Temperature	Top	10 to +50	°C	
14.	Storage Temperature	Tstor	0 to +60	°C	

Note:

* IL is 0.3 dB higher, RL is 5 dB lower and Optical Power is 1 W only for each connector added.

2 Drawings

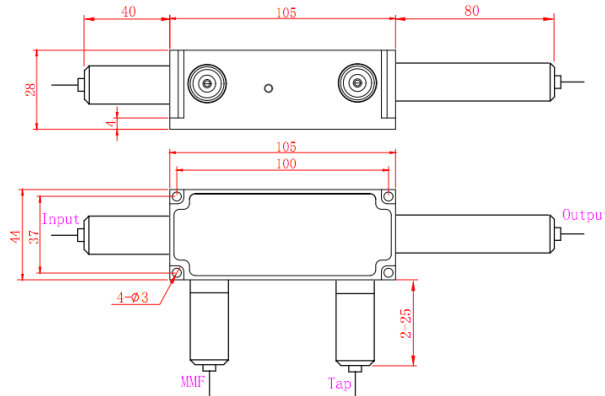

3 Device Label, Delivery Data, RoHS Requirement

Triple-Stone standard format. RoHS compliant.

4 Order Information

HPMTIBP-1-2-3-4-5-6-7-8-9-10-11-12

1.	Wavelength	03 - 1030 nm, 06 - 1064 nm, SS - Specify
2.	Handling Power	50 - 50 W, 100 - 100 W, SS - Specify
3.	Pass Bandwidth	08 - 8 nm, 14 - 14 nm, 22 - 22 nm, SS - Specify
4.	Coupling Ratio	0.1 - 0.1/99.9, 01 - 01/99, 05 - 05/95, 10 - 10/90, SS - Specify
5.	Fiber Type for Input	2 - PM1060L, 3 - PLMA-GDF-10/125-M, 4 - PLMA-GDF-14/125-UF, 5 - PLMA-GDF-20/400-M, 6 - PLMA-GDF-30/250-M, S - Specify
6.	Fiber Type for Output	2 - PM1060L, 3 - PLMA-GDF-10/125-M, 4 - PLMA-GDF-14/125-UF, 5 - PLMA-GDF-20/400-M, 6 - PLMA-GDF-30/250-M, S - Specify
7.	Fiber Type for Tap & MMF	13 - HI1060&MM 105/125 NA0.22, 23 - FUD-3584&MM 105/125 NA0.22, S - Specify
8.	Fiber Length	1 - 1.0 m, S - Specify
9.	Jacket Type	B - Bare fiber, S - Specify
10.	Connector Type for Tap	1 - FC/UPC, 2 - FC/APC, N - None, S - Specify
11.	Power Type	C - Continuous Wave, P - Pulse Application
12.	Working Axis	F - Fast axis blocked